

THIS DRAWING IS UNPUBLISHED. RELEASED FOR PUBLICATION
 © COPYRIGHT - By - ALL RIGHTS RESERVED.

REVISIONS				
P	LTR	DESCRIPTION	DATE	APVD
C1		REVISED PER ECR-15-006702	28JUL2015	NK PQ

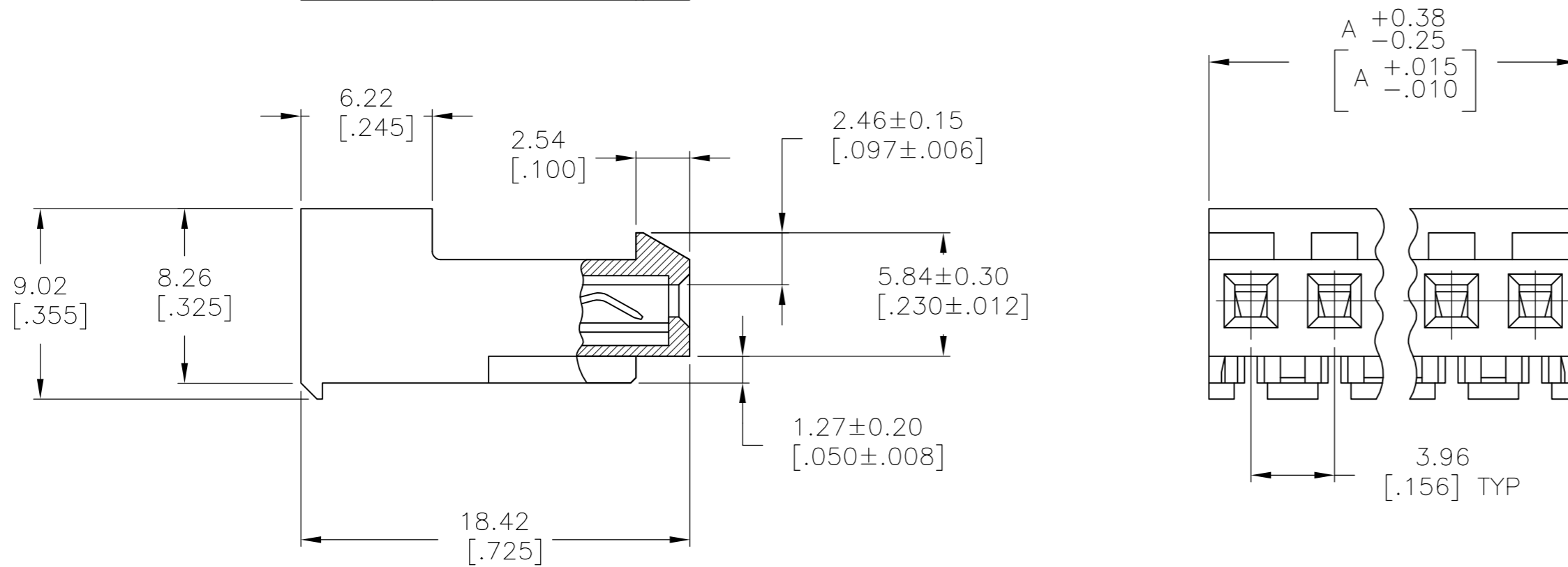
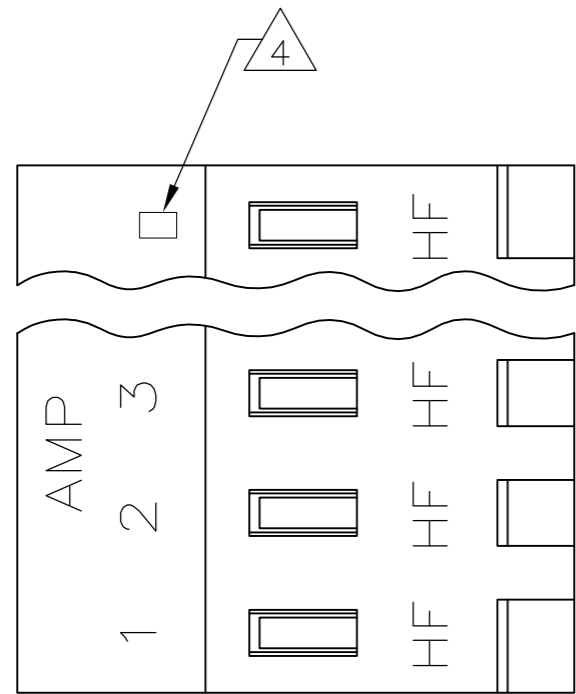

1 MATERIAL: CONNECTOR - NYLON UL94V-2 (RED).
 CONTACTS - 0.30[.012] THICK COPPER ALLOY BRIGHT TIN-LEAD
 0.00203[.000080] MIN THICK FOR -2 THRU -28
 - 0.30[.012] THICK COPPER ALLOY MATTE WHISKER
 MITIGATED TIN 0.00203[.000080] MIN THICKNESS
 OVER NICKEL UNDERPLATE FOR -32 THRU -58.

- 2. CONTACTS ACCEPT 22 AWG WIRE WITH 2.41[.095] MAX INSULATION DIAMETER.
- 3. CONTACTS MUST ACCEPT 1.14±0.03[.045±.001] SQUARE POST AND REMAIN LOCKED IN POSITION.
- 4. IDENTIFICATION NUMBER FOR LAST CIRCUIT MAY NOT APPEAR ON ALL ASSEMBLIES.
- 5. DIMENSIONS IN BRACKETS ARE IN INCHES.
- 6. HOUSING FEATURES ARE: CLOSED END WITH LOCKING RAMP.(HIGH FORCE CONTACT)

FINISH	DIM A	NO. OF CIRCUITS	PART NO.
TIN	23.77 [.936]	6	3-643193-6
TIN	19.81 [.780]	5	3-643193-5
TIN	15.85 [.624]	4	3-643193-4
TIN	11.89 [.468]	3	3-643193-3
TIN	7.92 [.312]	2	3-643193-2
TIN-LEAD	23.77 [.936]	6	643193-6
TIN-LEAD	19.81 [.780]	5	643193-5
TIN-LEAD	15.85 [.624]	4	643193-4
TIN-LEAD	11.89 [.468]	3	643193-3
OBsolete TIN-LEAD	7.92 [.312]	2	-643193-2-

THIS DRAWING IS A CONTROLLED DOCUMENT.		DWN 12FEB91	TE TE Connectivity	
		CHK 12FEB91		
DIMENSIONS: mm [INCHES]		APVD 20FEB91	NAME	
TOLERANCES UNLESS OTHERWISE SPECIFIED:		PRODUCT SPEC	MTA 156 CONNECTOR ASSEMBLY, 22 AWG, HIGH FORCE,SPECIAL	
0 PLC ± -		APPLICATION SPEC	SIZE	CAGE CODE
1 PLC ± -		108-1051	A2	00779
2 PLC ± -		114-1020	DRAWING NO	643193
3 PLC ± 0.13[.005]		WEIGHT	SCALE	SHEET
4 PLC ± -			4:1	1 of 1
ANGLES ± -		CUSTOMER DRAWING	REV	C1
MATERIAL 1	FINISH 1			